

Model: ZR16M3E-TWD

Data

Type: Hermetic piston compressors

Producer: Copeland

Series: ZR

Model: ZR16M3E-TWD

Technical data

Nominal motor power [HP]:	13
Displacement [m ³ /h]:	35,5
Sound pressure level :	69
Gross/Net weight [kg]:	114/103
Oil charge [dm ³]:	4,1

Electrical data

Power supply [V/~/Hz]:	1 3/8"
Locked rotor current [A]:	7/8"
Max. operating current [A]:	1 1/4"
Winding resistance [Ω]:	319/357

Connections

	<u>milimeters</u>	<u>inches</u>
Suction Rotolock valve connection:		1 3/4"
Discharge Rotolock valve connection:		1 1/4"
Suction connection with supplied sleeve:		1 3/8"
Discharge connection with supplied sleeve:		7/8"

Model: ZR16M3E-TWD

Capacity

R22

Cooling capacity [kW]

$t_c \setminus t_e$	-20	-15	-10	-5	0	5	10	15
20	15.83	19.88	24.59	30.09	36.52	44.01	-	-
25	15.42	19.40	23.96	29.23	35.36	42.48	50.72	-
30	14.83	18.76	23.20	28.28	34.14	40.91	48.72	57.71
35	14.03	17.95	22.31	27.22	32.83	39.28	46.69	55.21
40	13.03	16.96	21.25	26.03	31.42	37.57	44.62	52.68
45	-	15.77	20.02	24.68	29.89	35.78	42.48	50.12
50	-	-	18.60	23.18	28.22	33.87	40.26	47.51
55	-	-	-	21.49	26.40	31.84	37.94	44.83
60	-	-	-	-	24.41	29.66	35.50	42.06
65	-	-	-	-	22.23	27.33	32.94	39.19

Power input [kW]

$t_c \setminus t_e$	-20	-15	-10	-5	0	5	10	15
20	5.52	5.59	5.67	5.78	5.95	6.19	-	-
25	6.10	6.17	6.22	6.30	6.41	6.58	6.82	-
30	6.73	6.80	6.85	6.90	6.97	7.07	7.24	7.49
35	7.40	7.50	7.56	7.59	7.63	7.68	7.79	7.95
40	8.12	8.26	8.33	8.37	8.39	8.41	8.46	8.56
45	-	9.08	9.19	9.24	9.26	9.26	9.28	9.32
50	-	-	10.13	10.21	10.24	10.24	10.23	10.23
55	-	-	-	11.28	11.33	11.34	11.32	11.29
60	-	-	-	-	12.54	12.57	12.55	12.51
65	-	-	-	-	13.86	13.93	13.94	13.90

Model: ZR16M3E-TWD

Capacity

Current [A]

$t_c \setminus t_e$	-20	-15	-10	-5	0	5	10	15
20	12.59	12.59	12.56	12.53	12.55	12.66	-	-
25	13.25	13.28	13.25	13.22	13.22	13.29	13.47	-
30	13.95	14.00	13.99	13.95	13.94	13.98	14.11	14.38
35	14.70	14.78	14.79	14.76	14.73	14.75	14.84	15.05
40	15.55	15.67	15.70	15.67	15.64	15.63	15.69	15.85
45	-	16.69	16.74	16.73	16.69	16.67	16.69	16.81
50	-	-	17.95	17.95	17.92	17.88	17.88	17.96
55	-	-	-	19.38	19.35	19.31	19.28	19.32
60	-	-	-	-	21.02	20.98	20.94	20.94
65	-	-	-	-	22.97	22.92	22.87	22.85

Mass flow [kg/s]

$t_c \setminus t_e$	-20	-15	-10	-5	0	5	10	15
20	315.88	392.49	479.73	580.19	696.45	831.10	-	-
25	318.94	396.68	483.91	583.25	697.27	828.56	979.72	-
30	318.33	397.91	485.89	584.84	697.35	826.02	973.43	1 142.18
35	313.43	395.61	485.05	584.34	696.08	822.86	967.26	1 131.88
40	303.65	389.14	480.78	581.16	692.86	818.48	960.60	1 121.82
45	-	377.92	472.50	574.69	687.09	812.28	952.85	1 111.41
50	-	-	459.58	564.32	678.14	803.64	943.41	1 100.03
55	-	-	-	549.45	665.44	791.98	931.66	1 087.09
60	-	-	-	-	648.35	776.67	917.01	1 071.97
65	-	-	-	-	626.29	757.12	898.85	1 054.08

Model: ZR16M3E-TWD

Capacity

C.O.P. [W/W]

$t_c \setminus t_e$	-20	-15	-10	-5	0	5	10	15
20	2.87	3.56	4.34	5.21	6.14	7.11	-	-
25	2.53	3.15	3.85	4.64	5.52	6.46	7.43	-
30	2.20	2.76	3.39	4.10	4.90	5.78	6.73	7.70
35	1.90	2.39	2.95	3.59	4.31	5.11	6.00	6.94
40	1.60	2.05	2.55	3.11	3.75	4.47	5.27	6.15
45	-	1.74	2.18	2.67	3.23	3.86	4.58	5.38
50	-	-	1.84	2.27	2.76	3.31	3.94	4.65
55	-	-	-	1.91	2.33	2.81	3.35	3.97
60	-	-	-	-	1.95	2.36	2.83	3.36
65	-	-	-	-	1.60	1.96	2.36	2.82

Application range

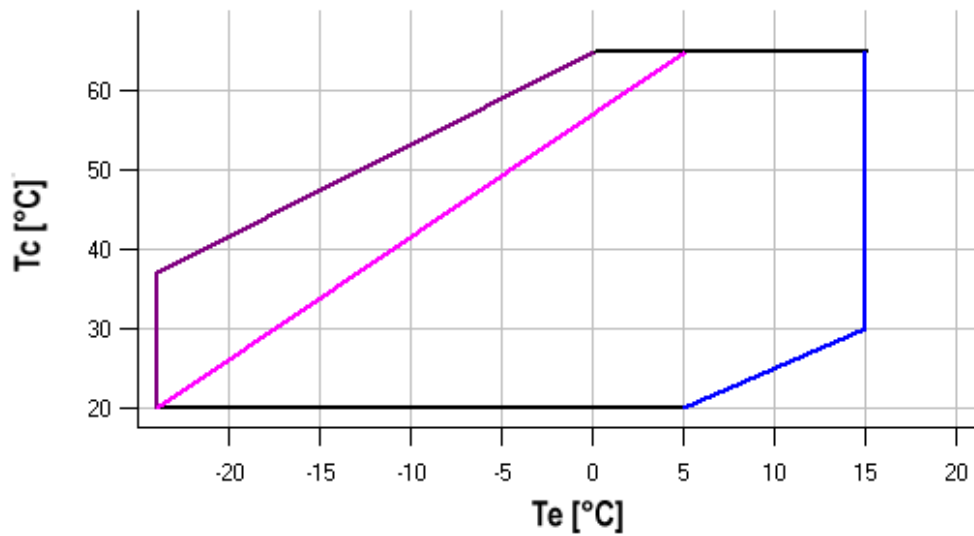

- Maximum evaporating temperature
- 25°C suction gas temperature
- 10K gas overheat

Operating conditions: 10K suction superheat, 0K subcooling

t_c - Condensing temperature [°C]

t_e - Evaporating temperature [°C]

Model: ZR16M3E-TWD

Capacity

R134a

Cooling capacity [kW]

$t_c \setminus t_e$	-15	-10	-5	0	5	10	15
30	11.58	14.64	18.33	22.67	27.72	33.49	40.03
35	11.00	13.92	17.45	21.63	26.50	32.08	38.43
40	10.42	13.18	16.53	20.53	25.19	30.57	36.70
45	9.86	12.42	15.58	19.37	23.82	28.97	34.85
50	-	11.68	14.62	18.18	22.39	27.29	32.91
55	-	-	13.66	16.97	20.92	25.55	30.89
60	-	-	12.72	15.76	19.43	23.77	28.81
65	-	-	-	14.56	17.93	21.96	26.68
70	-	-	-	-	16.44	20.13	24.51

Power input [kW]

$t_c \setminus t_e$	-15	-10	-5	0	5	10	15
30	4.39	4.44	4.51	4.61	4.76	4.95	5.21
35	5.00	5.06	5.12	5.20	5.31	5.46	5.66
40	5.61	5.68	5.74	5.81	5.90	6.01	6.16
45	6.23	6.32	6.39	6.45	6.53	6.62	6.74
50	-	6.98	7.07	7.15	7.22	7.30	7.39
55	-	-	7.80	7.90	7.98	8.05	8.13
60	-	-	8.60	8.72	8.81	8.89	8.96
65	-	-	-	9.62	9.74	9.84	9.91
70	-	-	-	-	10.77	10.89	10.98

Model: ZR16M3E-TWD

Capacity

Current [A]

$t_c \setminus t_e$	-15	-10	-5	0	5	10	15
30	13.12	13.12	13.13	13.17	13.24	13.38	13.58
35	13.55	13.54	13.54	13.55	13.60	13.69	13.83
40	14.04	14.04	14.03	14.04	14.06	14.12	14.23
45	14.58	14.61	14.61	14.62	14.64	14.68	14.77
50	-	15.25	15.28	15.30	15.33	15.37	15.44
55	-	-	16.03	16.08	16.13	16.18	16.26
60	-	-	16.87	16.96	17.04	17.12	17.21
65	-	-	-	17.93	18.06	18.18	18.29
70	-	-	-	-	19.19	19.36	19.52

Mass flow [kg/s]

$t_c \setminus t_e$	-15	-10	-5	0	5	10	15
30	267.75	331.96	407.34	494.11	592.49	702.72	825.02
35	267.40	331.06	406.30	493.33	592.38	703.66	827.41
40	267.02	329.72	404.39	491.26	590.54	702.46	827.25
45	266.93	328.25	401.93	488.21	587.31	699.44	824.83
50	-	326.96	399.24	484.51	582.99	694.91	820.48
55	-	-	396.62	480.46	577.90	689.19	814.53
60	-	-	394.41	476.39	572.37	682.60	807.28
65	-	-	-	472.61	566.72	675.45	799.05
70	-	-	-	-	561.25	668.08	790.17

Model: ZR16M3E-TWD

Capacity

C.O.P. [W/W]

$t_c \setminus t_e$	-15	-10	-5	0	5	10	15
30	2.64	3.30	4.06	4.91	5.83	6.76	7.69
35	2.20	2.75	3.41	4.16	4.99	5.88	6.79
40	1.86	2.32	2.88	3.53	4.27	5.09	5.95
45	1.58	1.97	2.44	3.00	3.65	4.38	5.17
50	-	1.67	2.07	2.54	3.10	3.74	4.46
55	-	-	1.75	2.15	2.62	3.17	3.80
60	-	-	1.48	1.81	2.20	2.67	3.21
65	-	-	-	1.51	1.84	2.23	2.69
70	-	-	-	-	1.53	1.85	2.23

Application range

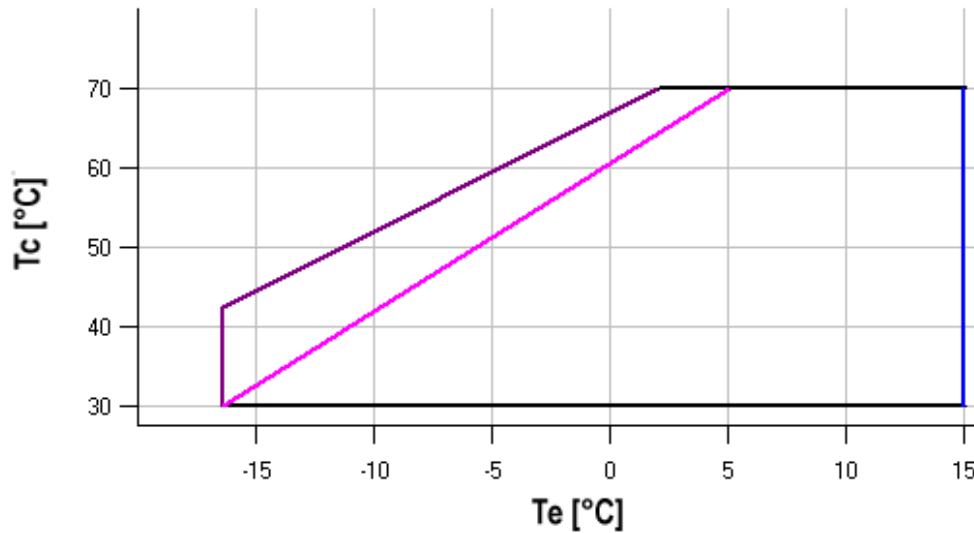

- Maximum evaporating temperature
- 25°C suction gas temperature
- 10K gas overheat

Operating conditions: 10K suction superheat, 0K subcooling

t_c - Condensing temperature [°C]

t_e - Evaporating temperature [°C]

Model: ZR16M3E-TWD

Capacity

R407C

Cooling capacity [kW]

t_c \ t_e	-20	-15	-10	-5	0	5	10	15
10	17.98	22.23	27.28	33.23	-	-	-	-
15	17.13	21.25	26.14	31.90	38.62	-	-	-
20	16.26	20.25	24.97	30.53	37.01	44.52	-	-
25	15.38	19.23	23.78	29.13	35.37	42.60	50.91	-
30	14.49	18.19	22.56	27.69	33.68	40.62	48.62	57.76
35	13.58	17.12	21.30	26.21	31.95	38.60	46.27	55.05
40	12.65	16.04	20.02	24.70	30.17	36.52	43.86	52.27
45	-	14.92	18.70	23.14	28.34	34.39	41.39	49.42
50	-	-	17.35	21.55	26.47	32.20	38.85	46.51
55	-	-	-	19.91	24.54	29.96	36.25	43.52
60	-	-	-	-	22.57	27.66	33.59	40.47
65	-	-	-	-	-	25.30	30.87	37.34

Power input [kW]

t_c \ t_e	-20	-15	-10	-5	0	5	10	15
10	4.39	4.44	4.57	4.81	-	-	-	-
15	4.81	4.83	4.90	5.05	5.33	-	-	-
20	5.29	5.30	5.33	5.41	5.60	5.92	-	-
25	5.84	5.85	5.86	5.90	6.01	6.24	6.60	-
30	6.45	6.49	6.50	6.51	6.57	6.71	6.97	7.39
35	7.13	7.21	7.24	7.24	7.27	7.35	7.53	7.83
40	7.87	8.01	8.08	8.10	8.11	8.16	8.26	8.47
45	-	8.90	9.03	9.08	9.10	9.12	9.18	9.32
50	-	-	10.08	10.19	10.23	10.26	10.29	10.37
55	-	-	-	11.42	11.51	11.55	11.58	11.63
60	-	-	-	-	12.94	13.02	13.06	13.09
65	-	-	-	-	-	14.65	14.72	14.76

Model: ZR16M3E-TWD

Capacity

Current [A]

$t_c \setminus t_e$	-20	-15	-10	-5	0	5	10	15
10	10.58	10.64	10.72	10.86	-	-	-	-
15	11.13	11.18	11.23	11.33	11.50	-	-	-
20	11.71	11.76	11.80	11.86	11.98	12.20	-	-
25	12.35	12.41	12.44	12.48	12.56	12.72	12.99	-
30	13.07	13.14	13.18	13.21	13.27	13.38	13.59	13.93
35	13.88	13.99	14.04	14.07	14.11	14.19	14.36	14.63
40	14.82	14.97	15.04	15.08	15.11	15.18	15.30	15.53
45	-	16.10	16.21	16.27	16.31	16.36	16.46	16.64
50	-	-	17.57	17.66	17.71	17.77	17.85	18.00
55	-	-	-	19.28	19.35	19.41	19.49	19.62
60	-	-	-	-	21.25	21.33	21.41	21.53
65	-	-	-	-	-	23.54	23.63	23.75

Mass flow [kg/s]

$t_c \setminus t_e$	-20	-15	-10	-5	0	5	10	15
10	319.12	391.42	474.80	570.83	-	-	-	-
15	317.01	389.09	472.28	568.14	678.25	-	-	-
20	314.07	385.95	468.96	564.68	674.66	800.47	-	-
25	310.32	382.03	464.89	560.47	670.34	796.07	939.22	-
30	305.79	377.34	460.06	555.53	665.31	790.97	934.09	1 096.22
35	300.51	371.91	454.52	549.89	659.60	785.21	928.30	1 090.43
40	294.48	365.77	448.27	543.57	653.23	778.81	921.89	1 084.04
45	-	358.93	441.35	536.59	646.22	771.79	914.88	1 077.06
50	-	-	433.78	528.98	638.59	764.17	907.29	1 069.53
55	-	-	-	520.76	630.37	755.97	899.15	1 061.46
60	-	-	-	-	621.58	747.23	890.47	1 052.87
65	-	-	-	-	-	737.95	881.28	1 043.79

Model: ZR16M3E-TWD

Capacity

C.O.P. [W/W]

$t_c \setminus t_e$	-20	-15	-10	-5	0	5	10	15
10	4.10	5.01	5.97	6.91	-	-	-	-
15	3.56	4.40	5.34	6.31	7.24	-	-	-
20	3.07	3.82	4.69	5.64	6.61	7.52	-	-
25	2.63	3.29	4.06	4.94	5.88	6.83	7.71	-
30	2.25	2.80	3.47	4.25	5.13	6.05	6.97	7.82
35	1.91	2.38	2.94	3.62	4.39	5.25	6.15	7.03
40	1.61	2.00	2.48	3.05	3.72	4.48	5.31	6.17
45	-	1.68	2.07	2.55	3.11	3.77	4.51	5.30
50	-	-	1.72	2.11	2.59	3.14	3.78	4.48
55	-	-	-	1.74	2.13	2.59	3.13	3.74
60	-	-	-	-	1.74	2.13	2.57	3.09
65	-	-	-	-	-	1.73	2.10	2.53

Application range

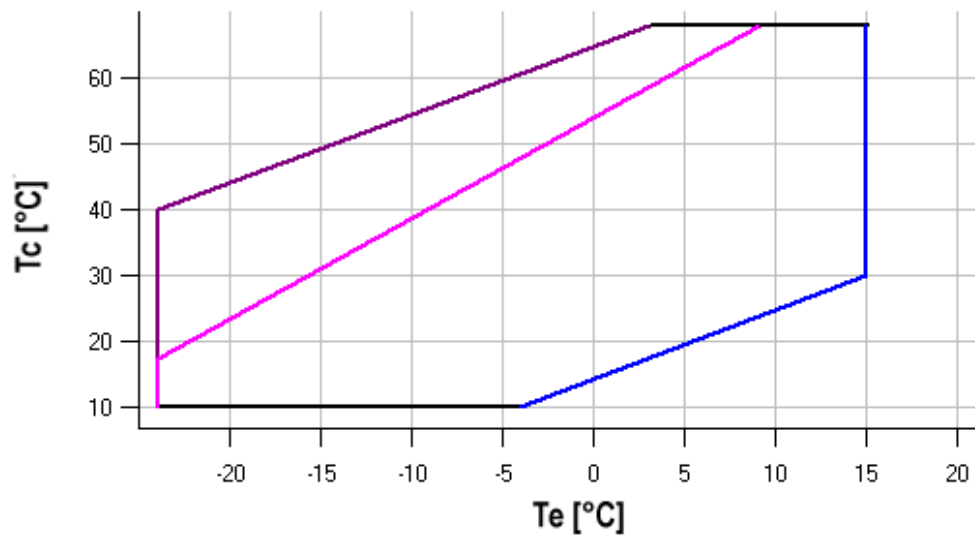

- Maximum evaporating temperature
- 25°C suction gas temperature
- 10K gas overheat

Operating conditions: 10K suction superheat, 0K subcooling

t_c - Condensing temperature [°C]

t_e - Evaporating temperature [°C]

Model: ZR16M3E-TWD

Dimensions

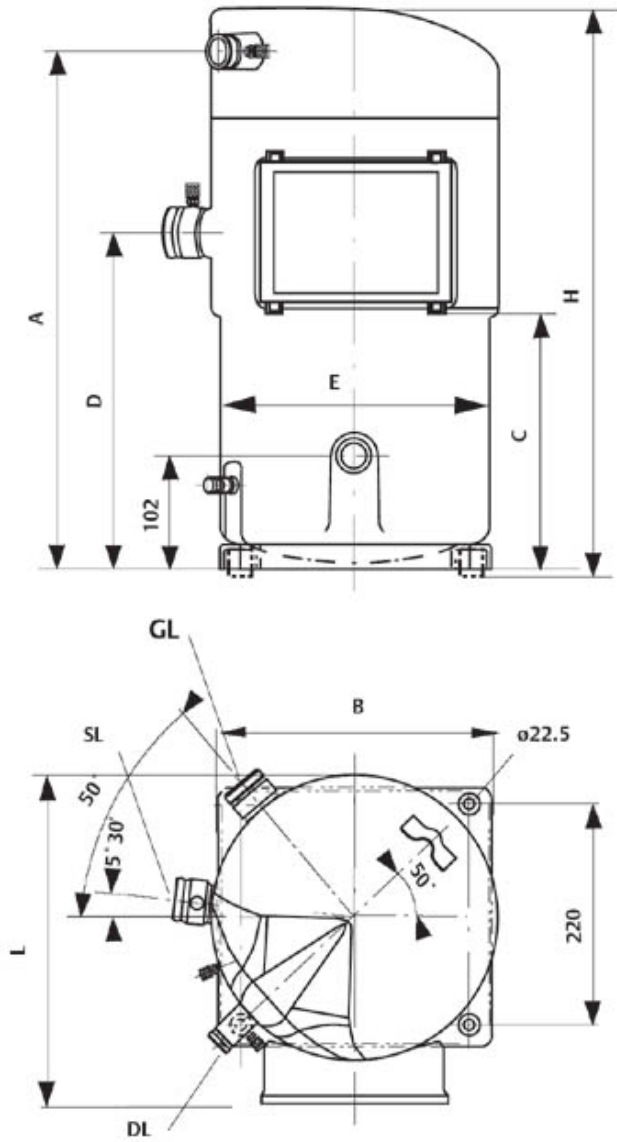

A	505 mm
B	268 mm
C	224 mm
D	318 mm
E	283 mm
H	545 mm
L	360 mm

Model: ZR16M3E-TWD

Image

